

The Brocade SilkWorm 3800 line of entry-to-enterprise Fibre Channel fabric switches provides both 1 and 2 Gbit/sec interfaces and includes a wide range of enhanced features to improve SAN security, availability, performance, and manageability.

SILKWORM 3800

Highlights

- Provides 16 ports in a single 1U enclosure with auto-sensing 1 Gbit/sec and 2 Gbit/sec interfaces for seamless integration with existing fabrics
- Increases security through hardware-enforced WWN zoning and optional Secure Fabric OS®
- Meets high-availability requirements with redundant, hot-pluggable components, automatic path rerouting, and extensive diagnostics
- Employs optional Brocade Inter-Switch Link (ISL) Trunking to create an 8 Gbit/sec data path between switches for higher performance
- Protects investments through backward and forward compatibility with Brocade SilkWorm Fibre Channel switches
- Provides the ability to scale from entry 2-switch fabrics to full-fabric enterprise capabilities

Improved Security, Availability, Performance, and Manageability

The Brocade® SilkWorm® 3800 line of 16-port, auto-sensing Fibre Channel switches significantly increases performance and functionality for Storage Area Networks (SANs). Based on third-generation Brocade ASIC technology, the SilkWorm 3800 line combines 1 Gbit/sec and 2 Gbit/sec Fibre Channel throughput with new features that greatly enhance switch operation. As a result, organizations can enjoy the advantages of higher security, availability, and performance, as well as centralized data management.

Designed for both entry and enterprise environments, the SilkWorm 3800 line integrates a variety of high-availability hardware and software features. The SilkWorm 3800 line is especially useful for organizations that want to upgrade their existing environment with minimal disruption. The switch line is fully interoperable with existing SilkWorm 1000 and 2000 series

switches—enabling both an entry fabric and a core-to-edge architecture that facilitates expansion, higher performance, and higher availability. When added to existing fabrics, the SilkWorm 3800 line automatically assigns individual switch addresses, establishes frame routes, and configures the internal name server.

HIGH AVAILABILITY THROUGHOUT THE FABRIC

The SilkWorm 3800 line is designed to provide high-availability switching at the core of small-to-medium-sized storage networks. The core-to-edge SAN model features high availability for the entire fabric through redundant network paths. Combining the proven reliability of the SilkWorm family with a wide range of optional Advanced Fabric Services, the SilkWorm 3800 line provides a SAN fabric capable of delivering overall system availability greater than 99.999 percent—the “five nines” of availability.

INCREASES PERFORMANCE

In addition, Brocade Fabric Shortest Path First (FSPF) enables the fabric to automatically isolate problems and reroute traffic around failed links onto alternate paths—ensuring availability for mission-critical enterprise applications.

INDUSTRY-LEADING PERFORMANCE

The SilkWorm 3800 line provides high performance with all ports capable of operating at 1 and 2 Gbit/sec (full-duplex) to enable 32 Gbit/sec of uncongested switch throughput. Auto-sensing and speed matching of 1 and 2 Gbit/sec traffic ensures interoperability between current 1 Gbit/sec devices and next-generation 2 Gbit/sec devices. With the optional Brocade Extended Fabrics feature and Dense Wave Division Multiplexing (DWDM) technology, storage networks can span up to 100 km over Metropolitan Area Networks (MANs) at full bandwidth—significantly increasing the level of disaster protection to help ensure the highest level of business continuance.

To provide even higher performance—as well as simplified management—optional Brocade ISL Trunking combines up to four ISLs between a pair of switches into a single, logical high-speed trunk running at up to 8 Gbit/sec (see Figure 1).

INTELLIGENCE WITHIN THE SWITCH

To improve security and manageability, a wire-speed Frame Filtering engine is built directly into the SilkWorm 3800 third-generation ASIC technology. This design enables new capabilities such as fabric zoning based on World Wide Name (WWN) to be enforced through hardware for greater security. Organizations can improve end-to-end performance analysis by measuring resource utilization on a fabric-wide basis. They can track data all the way from the source device to the destination device to quickly identify bottlenecks, optimize fabric configurations, and plan for when additional capacity will be required.

OPEN SAN MANAGEMENT

The SilkWorm 3800 line simplifies management by networking core and edge switches with Brocade Fabric OS, an embedded real-time operating system. This approach enables heterogeneous device connectivity, automatic discovery, data routing, and scalable connectivity. In addition, the Brocade Fabric Access API provides critical functions for integrating applications within the SAN environment. The API layer is currently used by more than 50 independent software vendors to develop feature-rich management applications that leverage the distributed intelligence in Brocade SANs.

Figure 1.
Optional ISL Trunking groups multiple ISLs to enable high-speed data traffic

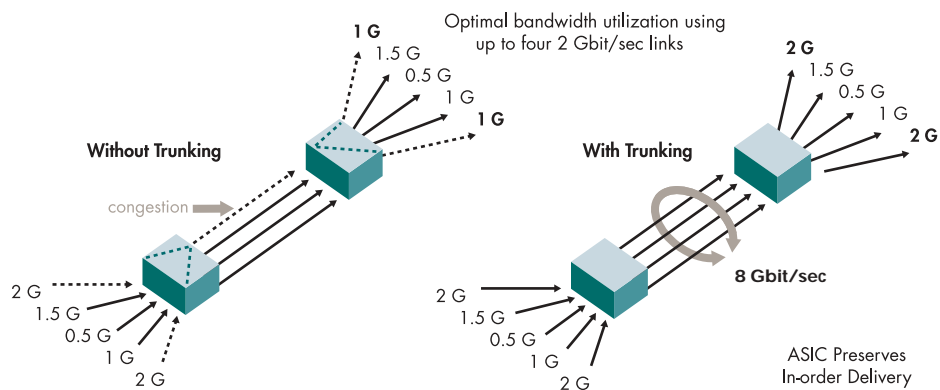

SEAMLESS UPGRADES, COST-EFFECTIVE MIGRATION, AND INVESTMENT PROTECTION

To help protect existing investments, the SilkWorm 3800 line provides a seamless upgrade path along with backward and forward compatibility with SilkWorm entry, midrange, and director-class offerings.

The SilkWorm 3800 line integrates with heterogeneous environments that include multiple operating systems such as Windows 2000 and NT, UNIX, Linux, HP-UX, Solaris, AIX, and others. As a result, organizations have the flexibility to build cost-efficient, and easy-to-manage enterprise SAN fabrics. These capabilities make the SilkWorm 3800 line ideal for applications such as LAN-free backup, server and storage consolidation, remote mirroring, and data replication.

A NEW LEVEL OF SAN SECURITY

Optional Brocade Advanced Zoning logically groups a SAN fabric into an unlimited number of secure private SANs (zones) to ensure that devices can access only their authorized storage resources. Zoning is enabled by the wire-speed Frame Filtering feature of the third-generation Brocade ASIC,

which filters and analyzes frames based on the content of fields in the first 64 bytes of the header. Organizations can specify hardware-enforced zones by WWNs on the SilkWorm 3800 line, simplifying administration while providing the highest level of security to control data access.

SUPERIOR RELIABILITY, AVAILABILITY, AND SERVICEABILITY

Advanced SilkWorm 3800 reliability features include the following:

- Highly reliable components and continuous monitoring of environmental conditions help reduce service costs.
- Power-On Self-Test (POST) and online diagnostics enable administrators to monitor and test ports while the switch is operating.
- Per-port statistics help administrators diagnose and isolate problem ports without disrupting switch operations.

INTELLIGENT SAN MONITORING

To simplify SAN monitoring and maintenance, the SilkWorm 3800 line provides the following functions:

- Fabric OS enables value-added Brocade SAN monitoring and management applications.

- Industry-standard Management Information Base (MIB) support enables Simple Network Management Protocol (SNMP)-based interfaces to access switch information.
- Administrators can manage switch configurations by using a command line interface, a Web-based Java application, or a centralized, multifabric management application.
- Self-learning features enable the fabric to automatically discover and register host server and storage devices.

MAXIMIZING SAN INVESTMENTS

Brocade and its partners offer complete, cost-effective SAN solutions to meet a wide range of technology and business requirements. These solutions include education and training, support, service, and professional services to help optimize SAN investments. For more information, contact an authorized Brocade sales partner or visit www.brocade.com.

FIBRE CHANNEL STANDARDS AND REVISIONS

FC-AL-2 Rev 7.0	FC-FLA Rev 2.7	FC-GS-3 Rev 7.01	FC-FG Rev 3.5	FC-FS Rev 1.7
FC-PH Rev 4.3	FC-PH-2 Rev 7.4	FC-PH-3 Rev 9.4	FC-PLDA Rev 2.1	FC-SW-2 Rev 5.4
FC-VI Rev 1.6	IPFC RFC 2625			

Systems Architecture

Fibre Channel ports	16 universal ports
Scalability	2-switch fabric, 4-switch fabric, up to a full fabric architecture with 239 switches maximum
Certified maximum	32 switches, 7 hops with optional full-fabric license; larger fabrics certified as required
Interoperability	SilkWorm II, SilkWorm Express, or any SilkWorm 2000 family switch
Performance	2.125 Gbit/sec line speed, full duplex
Aggregate bandwidth	64 Gbit/sec end-to-end
Fabric latency	<2 μ sec. with no contention, cut-through routing
Maximum frame size	2112-byte payload
Classes of service	Class 2, Class 3, Class F (inter-switch frames)
Port types	FL_Port, F_Port, and E_Port; self-discovery based on switch type (U_Port)
Data traffic types	Fabric switches support unicast, multicast (256 groups), and broadcast
Media types	Hot-pluggable, industry-standard Small Form-Factor Pluggable (SFP), LC connector; Short-Wavelength Laser (SWL); Long-Wavelength Laser (LWL); Extended Long-Wavelength Laser (ELWL); distance depends on fiber optic cable and port speed)
Laser	Short-wave up to 500 m (1,640 ft); long-wave up to 10 km (6.2 mi)
Fabric services	Simple Name Server, Registered State Change Notification (RSCN), Alias Server (multicast); and Brocade Advanced Zoning Optional fabric services include: QuickLoop, Fabric Watch, Extended Fabrics, Advanced Performance Monitoring, ISL Trunking, and Remote Switch
Options	Redundant power supply

Management

Supported software	Telnet, SNMP, WEB TOOLS, Fabric Manager (optional)
Management access	10/100 Ethernet (RJ-45), serial port
Diagnostics	POST and embedded online/offline diagnostics

Mechanical Specifications

Enclosure	Back-to-front airflow, power from rear 1U, 19-in.-EIA compliant
Size	Depth: 62.23 cm (24.50 in.) Height: 4.34 cm (1.71 in.) Width: 42.86 cm (16.87 in.)
Weight	Single power supply weight: 11.59 kg (25.6 lbs) Double power supply weight: 12.94 kg (28.5 lbs)

Environment

Temperature	Operating: 10° C to 40° C (50° F to 104° F) Nonoperating: -25° C to 70° C (-13° F to 158° F)
Humidity	Operating: 20% to 85% noncondensing at 40° C (104° F)
Altitude	Up to 3,000 m (9,800 ft)
Shock	Operating: 80 g's, 2.5 ms duration, half-sine
Vibration	Operating: 0.5 g sine, 0.4 grms random, 5-500 Hz Nonoperating: 2.0 g's sine, 1.1 grms random, 5-500 Hz

Power

AC Input	Nominal: 100 to 240 VAC, 2.5 A
Frequency	47 to 63 Hz



Corporate Headquarters

San Jose, CA USA
T: (408) 333-8000
info@brocade.com

European Headquarters

Geneva, Switzerland
T: +41 22 799 56 40
europe-info@brocade.com

Asia Pacific Headquarters

Tokyo, Japan
T: +81-3-5402-5300
apac-info@brocade.com

Latin America Headquarters

Miami, FL USA
T: (305) 716-4165
latinam-sales@brocade.com

© 2003 Brocade Communications Systems, Inc. All Rights Reserved. 08/03 GA-DS-135-03

Brocade, the Brocade B weave logo, Secure Fabric OS, and SilkWorm are registered trademarks of Brocade Communications Systems, Inc., in the United States and/or in other countries. FICON is a registered trademark of IBM Corporation in the U.S. and other countries. All other brands, products, or service names are or may be trademarks or service marks of, and are used to identify, products or services of their respective owners.

Notice: This document is for informational purposes only and does not set forth any warranty, expressed or implied, concerning any equipment, equipment feature, or service offered or to be offered by Brocade. Brocade reserves the right to make changes to this document at any time, without notice, and assumes no responsibility for its use. This informational document describes features that may not be currently available. Contact a Brocade sales office for information on feature and product availability. Export of technical data contained in this document may require an export license from the United States government.